

Prodotto	BMAI
Impiego	A parete, in mandata
Costruzione	Alluminio anodizzato

CAPITOLATO

Bocchetta industriale a grande portata ad alette regolabili passo 50 mm

FISSAGGIO

Con clips (viti frontali su richiesta)

ACCESSORI

Serranda di taratura in acciaio zincato con alette a movimento contrapposto.
Controtelaio di montaggio in lamiera di acciaio zincato.
Plenum (a richiesta) in acciaio zincato standard o isolato

DISEGNI

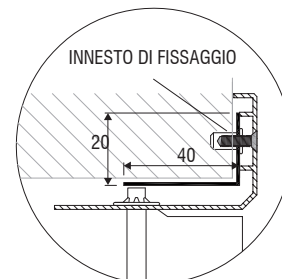
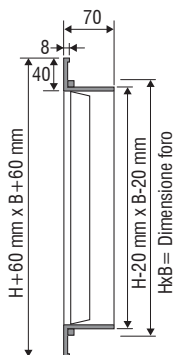
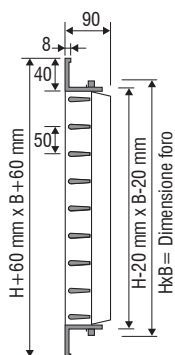

Telaio con zanche di fissaggio

BMAI-20

Alette frontali orizzontali, alette posteriori verticali

BMAI-2V

ESECUZIONE STANDARD
Alette frontali verticali, alette posteriori orizzontali

BMAI-1V

1 filare alette verticali

SEI

CTV2-BMAI

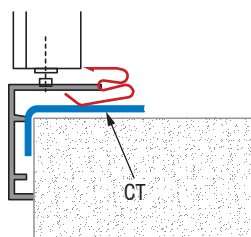

Standard

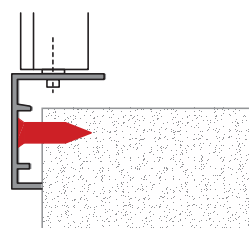

FISSAGGIO CON VITI

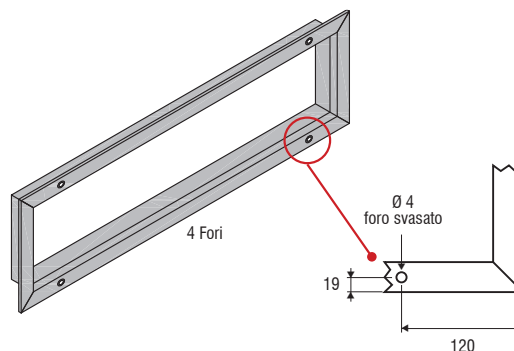

FORI

FISSAGGIO CON CLIPS

TABELLA DI SELEZIONE

BMAI Modello	A _k m ²	Q [m ³ /h]		L _{WA} [dB(A)]		X _(0,25) [m]		Dpt [Pa]	
		min	max	min	max	min	max	min	max
500x200	0,0776	690	1370	29	45	7,7	15,2	5	20
600x200	0,0938	830	1660	29	46	8,4	16,9	5	20
700x200	0,1101	980	1950	30	47	9,3	18,5	5	20
800x200	0,1265	1120	2240	31	48	9,9	19,9	5	20
900x200	0,1430	1270	2530	32	48	10,7	21,3	5	20
1000x200	0,1596	1410	2830	32	49	11,3	22,7	5	20
1200x200	0,1929	1710	3420	33	50	12,5	25,1	5	20
1400x200	0,2265	2010	4010	34	50	13,7	27,4	5	20
1500x200	0,2434	2160	4310	34	51	14,3	28,5	5	20
1800x200	0,2942	2610	5210	35	52	15,8	31,6	5	20
500x300	0,1183	1050	2100	31	47	9,6	19,3	5	20
600x300	0,1430	1270	2530	32	48	10,7	21,3	5	20
700x300	0,1679	1490	2970	32	49	11,6	23,2	5	20
800x300	0,1929	1710	3420	33	50	12,5	25,1	5	20
900x300	0,2181	1930	3860	33	50	13,4	26,8	5	20
1000x300	0,2434	2160	4310	34	51	14,3	28,5	5	20
1200x300	0,2942	2610	5210	35	52	15,8	31,6	5	20
1400x300	0,3454	3060	6120	36	52	17,2	34,5	5	20
1500x300	0,3711	3290	6570	36	53	17,9	35,8	5	20
1800x300	0,4486	3970	7950	37	54	19,8	39,8	5	20
500x400	0,1596	1410	2830	32	49	11,3	22,7	5	20
600x400	0,1929	1710	3420	33	50	12,5	25,1	5	20
700x400	0,2265	2010	4010	34	50	13,7	27,4	5	20
800x400	0,2603	2300	4610	34	51	14,7	29,5	5	20
900x400	0,2942	2610	5210	35	52	15,8	31,6	5	20
1000x400	0,3283	2910	5820	35	52	16,8	33,6	5	20
1200x400	0,3969	3510	7030	36	53	18,6	37,2	5	20
1400x400	0,4659	4130	8250	37	54	20,3	40,6	5	20
1500x400	0,5006	4430	8870	37	54	21,1	42,2	5	20
1800x400	0,6052	5360	10720	38	55	23,4	46,8	5	20
2000x400	0,6753	5980	11960	39	56	24,8	49,7	5	20
500x500	0,2013	1780	3570	33	50	12,8	25,7	5	20
600x500	0,2434	2160	4310	34	51	14,3	28,5	5	20
700x500	0,2857	2530	5060	35	51	15,5	31,1	5	20



TABELLA DI SELEZIONE

BMAI Modello	A _k m ²	Q [m ³ /h]		L _{WA} [dB(A)]		X _(0,25) [m]		Dpt [Pa]	
		min	max	min	max	min	max	min	max
800x500	0,3283	2910	5820	35	52	16,8	33,6	5	20
900x500	0,3711	3290	6570	36	53	17,9	35,8	5	20
1000x500	0,4141	3670	7340	37	53	19,0	38,1	5	20
1200x500	0,5006	4430	8870	37	54	21,1	42,2	5	20
1400x500	0,5877	5200	10410	38	55	23,0	46,1	5	20
1500x500	0,6315	5590	11190	39	55	23,9	47,9	5	20
1800x500	0,7634	6760	13520	39	56	26,5	53,1	5	20
2000x500	0,8518	7540	15090	40	57	28,2	56,4	5	20
600x600	0,2942	2610	5210	35	52	15,8	31,6	5	20
800x600	0,3969	3510	7030	36	53	18,6	37,2	5	20
900x600	0,4486	3970	7950	37	54	19,8	39,8	5	20
1000x600	0,5006	4430	8870	37	54	21,1	42,2	5	20
1200x600	0,6052	5360	10720	38	55	23,4	46,8	5	20
1400x600	0,7105	6290	12590	39	56	25,5	51,1	5	20
1500x600	0,7634	6760	13520	39	56	26,5	53,1	5	20
1800x600	0,9228	8170	16350	40	57	29,4	58,9	5	20
2000x600	1,0298	9120	18240	41	58	31,2	62,5	5	20
800x800	0,5354	4740	9480	38	54	21,9	43,8	5	20
900x800	0,6052	5360	10720	38	55	23,4	46,8	5	20
1000x800	0,6753	5980	11960	39	56	24,8	49,7	5	20
1200x800	0,8164	7230	14460	40	56	27,5	55,1	5	20
1400x800	0,9584	8490	16980	41	57	30,1	60,1	5	20
1500x800	1,0298	9120	18240	41	58	31,2	62,5	5	20
1800x800	1,2449	11020	22050	42	58	34,6	69,3	5	20
2000x800	1,3891	12300	24610	42	59	36,8	73,6	5	20
1000x1000	0,8518	7540	15090	40	57	28,2	56,4	5	20
1200x1000	1,0298	9120	18240	41	58	31,2	62,5	5	20
1400x1000	1,2089	10710	21410	42	58	34,1	68,2	5	20
1500x1000	1,2989	11500	23010	42	59	35,5	71,0	5	20
1800x1000	1,5703	13910	27810	43	60	39,3	78,7	5	20
2000x1000	1,7522	15520	31040	43	60	41,8	83,5	5	20

DIAGRAMMA DI SCELTA RAPIDA

